

INSTALLER: THESE INSTRUCTIONS MUST BE CONVEYED TO AND REMAIN WITH THE HOMEOWNER.

THIS FIREPLACE HAS BEEN TESTED AND LISTED BY WARNOCK HERSEY LTD. TO STANDARDS: ULC S610-M87, UL 127-1992, FOR ZERO CLEARANCE FIREPLACES, TO ULC S639-M87 FOR STEEL LINER ASSEMBLIES FOR SOLID FUEL BURNING MASONRY FIREPLACES AND TO CAN/ULC-S627-M90 FOR SPACE HEATERS FOR USE WITH SOLID FUELS.



NAPOLEON

FIREPLACES

SOLID FUEL BURNING - ZERO CLEARANCE

INSTALLATION AND OPERATION INSTRUCTIONS
FOR HI-TECH LISTED FIREPLACE

MODEL NZ25

WARNING: *If this fireplace is not properly installed, a house fire may result.*

FOR YOUR SAFETY

Follow the installation directions. This fireplace can be very hot when burning. Combustible materials such as firewood, wet clothing, etc. placed too close can catch fire. Children and pets must be kept from touching the fireplace when it is hot. The chimney must be sound and free of cracks. Before installing this unit, contact the local building or fire authority and follow their guidelines.

Operate only with the door tightly closed. Burn wood behind the log retainer directly on the firebricks. Do not use an elevated grate or otherwise raise the fire. This fireplace is designed to burn natural wood only. Higher efficiencies and lower emissions generally result when burning air dried seasoned hardwoods, as compared to softwoods or to green or freshly cut hardwoods. Do not start a fire with chemicals or fluids such as gasoline, engine oil, etc. Do not burn treated wood, coal, charcoal, coloured paper, cardboard, solvents or garbage. Do not let the fireplace become hot enough for any part to glow red.

**Wolf Steel Ltd., RR#1, 9 Napoleon Rd.,
Barrie, ON., Canada L4M 4Y8 (705)721-1212**

Fax: (705)722-6031 Email: ask@napoleon.on.ca
Web: www.napoleon.on.ca





TABLE of CONTENTS

PG 2-5	INTRODUCTION Warranty General Instructions General Information Care of Glass & Plated Parts	PG 11	OPTIONAL BLOWER
5-6	HI-EFFICIENCY HEATING Four Options Location & Clearance	12	NZ25 FEATURES Controlling Combustion Air Achieving Proper Draft
6-7	INSTALLATION / FRAMING Framing Outside Combustion Air Mantle Clearance Hearth Extension	12-13	OPERATING INSTRUCTIONS Fuel Loading and Burn Cycle Ash Removal Procedures Operating Instructions
8-10	CHIMNEY INSTALLATION Adding Chimney Sections Offset Chimney Installation Installing Flashing And Storm Collar Connection to a Masonry Chimney	14	MAINTENANCE Gasket / Baffle Replacement Creosote Formation And Removal Run-Away or Chimney Fire Fire Extinguishers and Smoke Detectors Woodpile Maintenance
10	FINISHING Firebrick Removal Attaching the Handle	14-15	REPLACEMENTS Ordering Replacement Parts Replacement Parts Accessories
		16	TROUBLE SHOOTING

PLEASE RETAIN THIS MANUAL FOR FUTURE REFERENCE

Congratulations on the purchase of your Napoleon hi-tech, high efficient solid fuel burning fireplace! It has been extensively tested in Canadian and American laboratories.

NAPOLEON wood fireplaces are manufactured under the strict Standard of the World Recognized ISO9002 Quality Assurance Certificate.

NAPOLEON products are designed with superior components and materials, assembled by trained craftsmen who take great pride in their work. The complete fireplace is thoroughly inspected by a qualified technician before packaging to ensure that you, the customer, receives the quality product that you expect from NAPOLEON.

NAPOLEON WOOD FIREPLACE PRESIDENT'S LIFETIME LIMITED WARRANTY

The following materials and workmanship in your new NAPOLEON wood fireplace are warranted against defects for as long as you own the fireplace. This covers: combustion chamber, heat exchanger, stainless steel baffle retainer, ceramic glass (thermal breakage only), gold plated parts against tarnishing, porcelainized enamelled components, aluminum extrusion trims ashdrawer, and cast iron castings.

Electrical (110V) components and wearable parts such as blowers, thermal switch, switches, wiring, firebrick, gasketing, and high temperature paint are covered and NAPOLEON will provide replacement parts free of charge during the first year of the limited warranty.

Labour related to warranty repair is covered free of charge during the first year. Repair work, however, requires the prior approval of an authorized company official. Labour costs to the account of NAPOLEON are based on a predetermined rate schedule and any repair work must be done through an authorized NAPOLEON dealer.

CONDITIONS AND LIMITATIONS

NAPOLEON warrants its products against manufacturing defects to the original purchaser only -- i.e., the individual or legal entity (registered customer) whose name appears on the warranty registration card filed with NAPOLEON -- provided that the purchase was made through an authorized NAPOLEON dealer and is subject to the following conditions and limitations:

This factory warranty is non-transferable and may not be extended whatsoever by any of our representatives.

The wood fireplace must be installed by an authorized service technician or contractor. Installation must be done in accordance with the installation instructions included with the product and all local and national building and fire codes.

This limited warranty does not cover damages caused by misuse, lack of maintenance, accident, alterations, abuse or neglect and parts installed from other manufacturers will nullify this warranty.

This limited warranty further does not cover any scratches, dents, corrosion or discolouring caused by excessive heat, abrasive and chemical cleaners nor chipping on porcelain enamel parts, nor any venting components used in the installation of the fireplace.

In the first year only, this warranty extends to the repair or replacement of warranted parts which are defective in material or workmanship provided that the product has been operated in accordance with the operation instructions and under normal conditions.

After the first year, with respect to the President's Limited Lifetime Warranty, NAPOLEON may, at its discretion, fully discharge all obligations with respect to this warranty by refunding to the original warranted purchaser the wholesale price of any warranted but defective part(s).

After the first year, NAPOLEON will not be responsible for installation, labour or any other costs or expenses related to the reinstallation of a warranted part, and such expenses are not covered by this warranty.

Notwithstanding any provisions contained in the President's Limited Lifetime Warranty, NAPOLEON'S responsibility under this warranty is defined as above and it shall not in any event extend to any incidental, consequential or indirect damages.

This warranty defines the obligations and liability of NAPOLEON with respect to the NAPOLEON wood fireplace and any other warranties expressed or implied with respect to this product, its components or accessories are excluded.

NAPOLEON neither assumes, nor authorizes any third party to assume, on its behalf, any other liabilities with respect to the sale of this product. NAPOLEON will not be responsible for: over-firing, downdrafts, spillage caused by environmental conditions such as rooftops, buildings, nearby trees, hills, mountains, inadequate vents or ventilation, excessive venting configurations, insufficient makeup air, or negative air pressures which may or may not be caused by mechanical systems such as exhaust fans, furnaces, clothes dryers, etc.

Any damages to fireplace, combustion chamber, heat exchanger, brass trim or other component due to water, weather damage, long periods of dampness, condensation, damaging chemicals or cleaners will not be the responsibility of NAPOLEON.

The bill of sale or copy will be required together with a serial number and a model number when making any warranty claims from your authorized dealer. The warranty registration card must be returned within fourteen days to register the warranty.

NAPOLEON reserves the right to have its representative inspect any product or part thereof prior to honouring any warranty claim.

ALL SPECIFICATIONS AND DESIGNS ARE SUBJECT TO CHANGE WITHOUT PRIOR NOTICE DUE TO ON-GOING PRODUCT IMPROVEMENTS. NAPOLEON® IS A REGISTERED TRADEMARK OF WOLF STEEL LTD. PATENTS U.S. 5.303.693.801 - CAN. 2.073.411, 2.082.915. © WOLF STEEL LTD.

INTRODUCTION

GENERAL INFORMATION

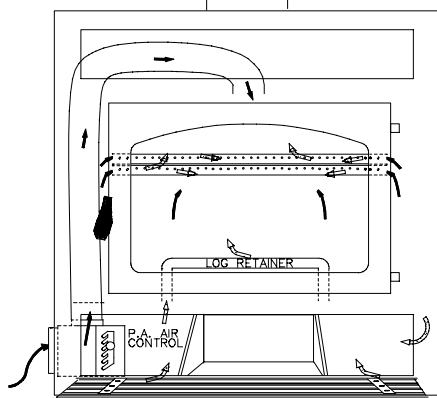

FIGURES 1

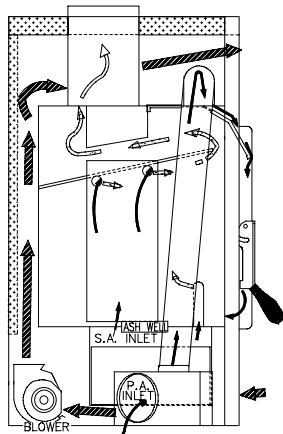

This is the most efficient, simple and trouble free woodburning system we know of and works as follows:

Primary combustion air enters through the air control inlet box regulated by a draft control, travels up the side through a duct and enters the top center of the combustion chamber into a preheating airwash located across the top and then down the window to feed the fire and also to ensure that the glass remains clean.

Secondary air feeds directly into the combustion chamber at hearth level through the log retainer and also through inlets located at the bottom back corner of the combustion chamber. This air travels up the riser to the four secondary air tubes located at the top and shoots out laterally to oxidize the gases rising to the smoke exit.

The combustion chamber is lined with high-temperature firebrick on all sides, and across the bottom to maintain a high temperature in the combustion chamber so that gases mixing with the preheated air from the secondary air tubes are easily ignited and burned. Indeed, it is fascinating to watch flames flickering much of the time from the secondary air tubes. The fireplace sides and back permit a zero clearance installation and direct the heat upwards and forwards into the room. Be sure to provide sufficient combustion air. There are many other appliances in your home competing for air such as a kitchen range hood, forced air heating devices or a bathroom exhaust fan.

If the outside air feature is utilized, you will never experience a shortage of combustion air. If you choose not to utilize outside air and experience draft or smoking problems, you may need to open a door or window.

After extended periods of non-operation such as following a vacation or a warm weather season, the fireplace may emit a slight odour for a few hours. This is caused by dust particles in the firebox burning off. Open a window to sufficiently ventilate the room.

GENERAL INSTRUCTIONS

Do not use makeshift compromises during installation.

All venting connections must be in compliance with the chimney manufacturers installation instructions.

Do not block or restrict air, grille or louvre openings!

Clearances referred to throughout this manual are the minimum requirements.

Your Napoleon fireplace must be installed in accordance with all national and local building code standards and the standard of Chimney and Fireplaces, Vents and Solid Fuel Burning Appliances NFPA #211. Consult the authority having jurisdiction (such as municipal building department, fire department, fire prevention bureau, etc.) to determine the need to obtain a permit. If you are in doubt about the proper installation for your situation, contact your dealer or local building or fire official. The manufacturer does not guarantee that this fireplace and its options will completely heat your entire home. Expansion / contraction noises during heating up and cooling down cycles are normal and to be expected.

It is recommended that the fireplace to be secured to the floor. Use the pallet packing brackets to accomplish this.

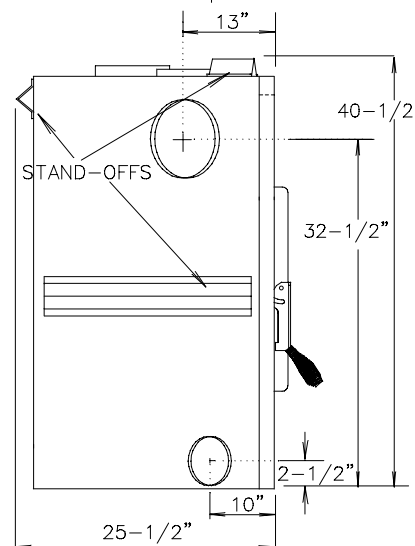
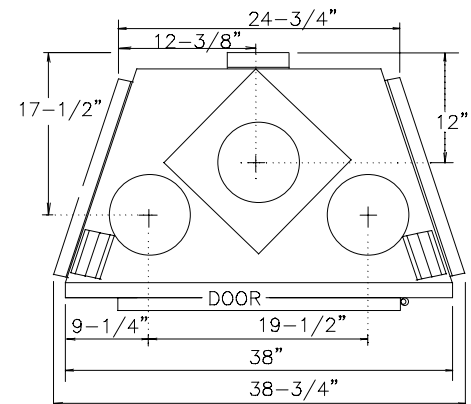

FIGURES 2

Burning your unit with the ash dump door open or ajar creates a fire hazard that may result in discoloration to the gold plated door, internal damage to the fireplace or a house and/or chimney fire.

CARE OF GLASS AND PLATED PARTS

If the glass is not kept clean permanent discolouration and / or blemishes may result. Normally a hot fire will clean the glass. The most common reasons for dirty glass include: not using sufficient fuel to get the stove thoroughly hot, using green or wet wood, closing the draft so far that there is insufficient air for complete combustion. If it is necessary to clean the glass, use a soft cloth with a non-abrasive cleaner. **DO NOT CLEAN THE GLASS WHEN HOT!**

The glass is very strong but do not let burning fuel rest or fall against it and always close the door gently. NEVER FORCE IT SHUT! If the glass should ever crack while the fire is burning, do not open the door until the fire is out and do not operate the stove again until the glass has been replaced with a new 5mm thick piece of ceramic glass, available from your Napoleon / Wolf Steel Ltd. dealer. **DO NOT SUBSTITUTE MATERIALS.** To remove the door, open and lift out; remove the screws and brackets holding the glass in place. Remove all broken glass. Wrap the edges of the new glass with a U-shaped strip of fiberglass gasket, covering 1/4" on each side. Place this gasketed glass in position and replace the brackets and screws. When finished, you should be able to move the glass slightly, horizontally and vertically.

Do not use abrasive cleaners to clean plated parts. Buff lightly with a clean dry cloth.

Prolonged high temperature burning with the door ajar may cause a permanent rainbowing effect on the lower edge of a gold plated door.

HI-EFFICIENCY HEATING

FOUR OPTIONS

For a basic hi-efficiency fireplace, blowers are not needed, however, they are recommended for extra heat output and efficient air circulation. This can be especially important if the fireplace is to be used as a major source of heat. Without the use of blowers, the Napoleon Model NZ25 will operate as a regular hi-efficiency fireplace.

A BLOWER KIT (NZ62) may be purchased with the option of adding up to one additional blower. These blowers are installed in the rear of the unit and are used to direct the heat into the room where the fireplace is located. The blowers are controlled, by a variable speed switch, located inside the fireplace.

A THERMOSTATIC AIR CONTROL (NZ690KT), may be used for constant heat, complete with automatic damper and thermostat, wall mounted in the room containing the fireplace, and at least **10 feet (minimum) from the fireplace.** This option allows your room temperature to be kept as evenly controlled as it would with other fuels while still enjoying the comfort of wood heat.

THE HOT AIR GRAVITY VENT SYSTEM (NZ220) may be used to distribute heat to an adjoining room (located either above, or beside the room containing the fireplace) by way of vents, eliminating the need of an additional blower. While this system may be used in conjunction with the optional blowers, it could reduce the flow of hot air being distributed to additional rooms. It must be experimented with and the dampers adjusted manually to suit your requirements. This may take a few attempts; thereafter adjustments should no longer be required as is normally experienced with your central heating system registers. **The hot air vent must be installed in an upward direction! NEVER install in a downward direction.** Figures 4c, 4d & 4e. The hot air gravity vent system is not be connected to a central heating system (for this application use the NZ62CH). No more than two hot air gravity vents can be installed to fireplace. Individual vent runs are not to exceed 10 feet.

All hot air gravity vents must be insulated.

A CENTRAL HEATING SYSTEM (NZ62CH) may be used to heat rooms up to 50 feet from the unit. A wall mounted thermostat located in the room to be heated controls the blower supplying warm air from the room containing the fireplace. If a hot air duct system exists, the central heat blower may safely be tied into this system to reduce the amount of new ducting required. Consult with a heating specialist to ensure a proper duct layout for your home.

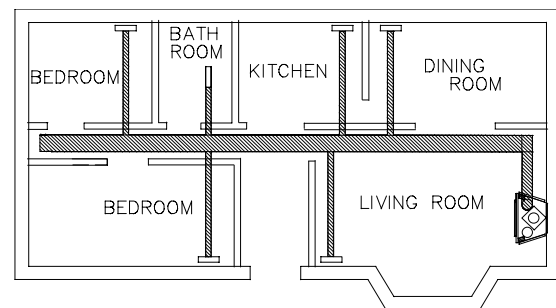

EXAMPLE OF REMOTE DUCTING SYSTEM

FIGURES 3

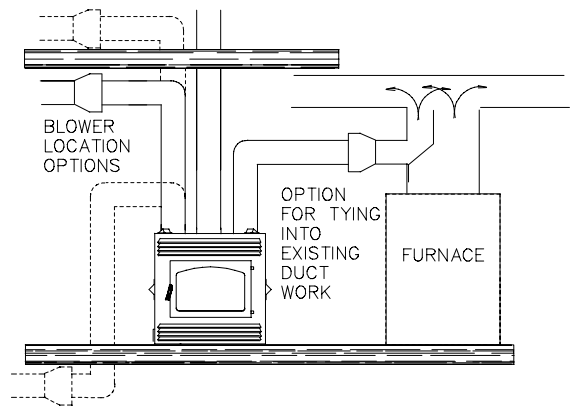

These options may be incorporated with one another. If the optional blowers are to be installed, make provision during framing to route a 110 volt power line to the fireplace. Detailed installation instructions are included with each venting kit.

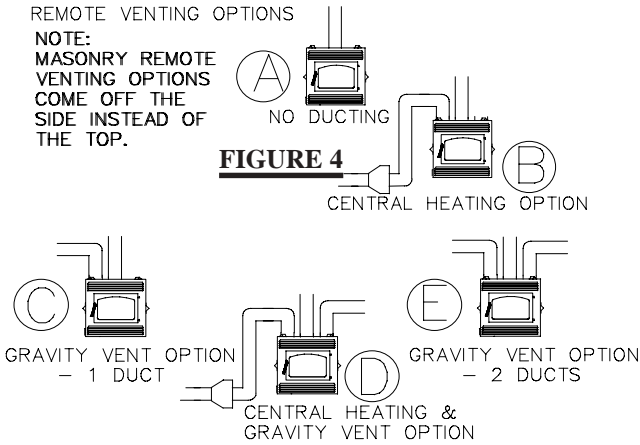

LOCATION AND CLEARANCES

The fireplace must be installed against finished walls. Do not install against a vapour barrier or exposed insulation.

While the fireplace can be installed directly on the floor, a non-combustible hearth extension is required in front of the fireplace, that must not be built higher than the bottom of the fireplace to avoid air flow blockage. It may therefore be advisable to build the fireplace on a raised platform. The minimum distance between the edge of the fireplace and any adjacent wall, at right angles to it, is 21 inches. A wall projecting at 45° from the outer edge of the fireplace is allowed; projections into this area are permitted. Do not install into any area having a height less than 6 feet (ceiling to fireplace bottom, excluding hearth height). **See Section on Framing.** The location of windows, doors and the traffic flow in the room where the stove is to be located should be considered. If possible, you should choose a location where the chimney will pass through the house without cutting a floor or roof joist.

MAINTAIN THESE MINIMUM CLEARANCES TO COMBUSTIBLES:

- 0" - FIREPLACE STAND-OFFS (TOP, REAR, & SIDES)
- 2" - CHIMNEY
- 1" - HOT AIR GRAVITY DUCTWORK

SEE 'FRAMING' SECTION:

- top of unit to ceiling: 32½" - TOP-VENTED ENCLOSURE
- 44½" - NON-VENTED ENCLOSURE

Clearance from combustibles to furnace hot air duct work as specified by the furnace manufacturer is satisfactory. No additional clearances are required.

Do not pack air space, created between the stand-offs and combustibles, with insulation or any other material.

Objects placed in front of the fireplace must be kept a minimum of 48" away from the front face of the unit.

INSTALLATION / FRAMING

FRAMING

The fireplace should be framed using 2x4 lumber as shown in **Figure 5**. The fireplace should be secured to the floor. Use the pallet packing brackets to accomplish this. If ducting is to be installed, the minimum enclosure ceiling height is 7 feet. Without ducting, the ceiling height may be brought down to a minimum of 6 feet. However a fireplace enclosure with a height less than 7 feet must be provided with sufficient air circulation to avoid a fire hazard. Install ventilation grilles (minimum openings of 40 sq. inches) at both floor and ceiling levels of the enclosure. These grilles must not restrict the flow of heat by more than 25%.

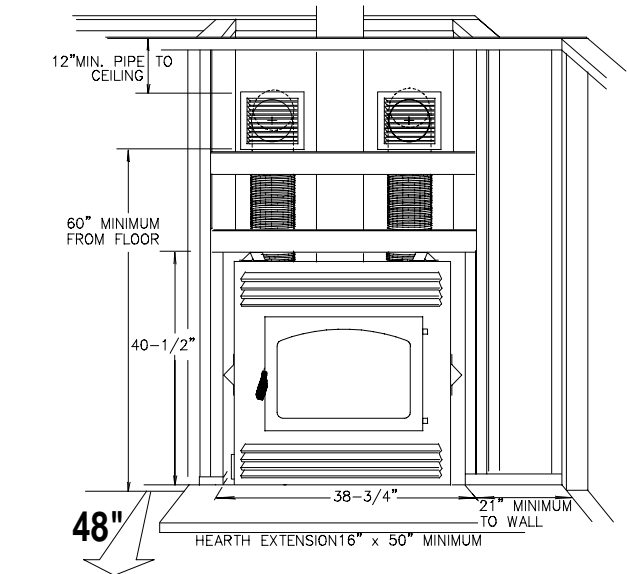

FIGURES 5

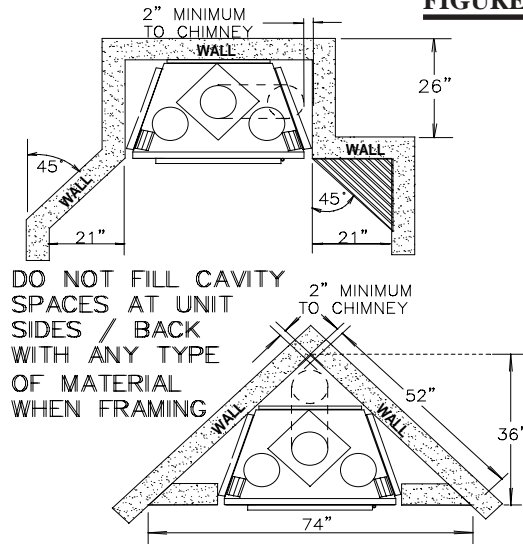

Do not place insulation into the enclosure around the fireplace or the chimney. Placed in this space, it may cause the adjacent wood to overheat and catch on fire.

Combustible materials may be installed flush with the front of the fireplace but must not cover any of the black painted surface of the fireplace front. Non-combustible material (brick, stone, or ceramic tile) may protrude. Pull out the nailing tabs, attached on either side of the fireplace and secure to the 2x4 framing to facilitate drywall installation.

Do not build shelves or cupboards into the area above the fireplace. Do not add a hood.

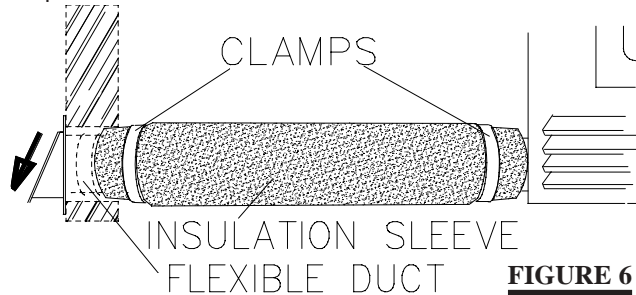

FIGURE 6

OUTSIDE COMBUSTION AIR

The Napoleon Model NZ25 has the option of taking outside air directly into the fireplace through the opening on the left hand side or taking inside air through the lower front louvres or a combination of both.

If the optional fresh air kit (available through your Napoleon / Wolf Steel Ltd. dealer) is installed, it must not draw air from the attic or garage. It may only come from outside the house. The maximum length of the 4 inch air duct is 20 feet; thereafter enlarge the duct to a 6 inch diameter.

Decide on the most convenient location for the fresh air inlet duct and hood which may be installed above or below floor level.

Make a 5 inch hole in an outside wall of the house. From outside, place the fresh air hood into the hole, open side down.

At each end, carefully pull back the insulation sleeve exposing the flexible duct. Place the insulated flexible duct over the fresh air hood and over the fireplace outside air connector. Carefully push the insulation sleeve back over the duct. Using the clamps, fasten the insulated duct into place on both sides. For outside air only, re-install the inside air cover plate, shown in **FIGURE 22**, to cover the control box inside air opening. **See Section on Combustion Air Control.**

MANTLE CLEARANCES

Mantle clearance can vary according to the mantle depth.

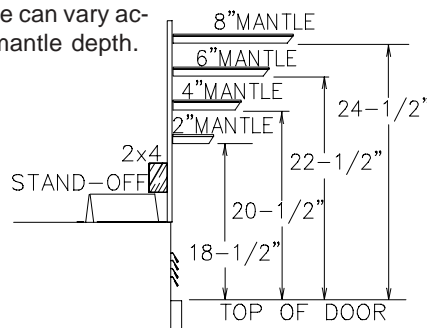

FIGURE 7

HEARTH EXTENSION

An acceptable 16" x 50" non-combustible (ie: brick, stone or ceramic tile) hearth extension must be installed. Ensure that the gap between the fireplace and a factory-built hearth extension is sealed with sand/cement grout or covered with a metal strip (or both) to prevent sparks and embers from falling into this area. A raised hearth together with the fireplace built on a raised platform is recommended for easier wood loading and fire viewing.

A chimney venting the fireplace shall not vent any other appliance.

The minimum overall chimney height from the top of the fireplace is 15 feet.

Factory-built chimney systems for use in dwellings constructed for three or more families must be enclosed above the room in which the fireplace is located. This enclosure must have a fire resistance rating equal to or greater than that of the floor or roof assembly through which they pass.

If the chimney system is enclosed within the attic area, a rafter radiation shield is required.

The chimney should not be built with an offset angle in excess of 45°.

The chimney must extend at least 3 feet above its point of contact with the roof and at least 2 feet higher than any wall, roof or building within 10 feet. Figure 13.

If the chimney extends more than 5 feet above the roof, it must be secured using a roof brace or guide wires.

Ensure that minimum clearances are maintained. Portions of the chimney that extend through accessible spaces must always be encased to avoid personal contact with the chimney and thereby avoid damage to the chimney.

A raincap must be installed to avoid internal damage and corrosion.

The chimney must be supported at a maximum of 20 foot intervals (approx. 200 lbs/20 ft).

CHIMNEY INSTALLATION

This fireplace was tested to CAN/ULC S610-M87 Zero Clearance Fireplace Safety Test Standard. In accordance with this standard, the unit may be connected to any accepted chimney listed to ULC S-629. The following 7" factory-built chimney systems may be used:

MANUFACTURER	LISTED TO ULC S610-M87:		
	MODEL #	MAXIMUM # OF OFFSETS (45° MAX.) (30° MAX.)	
OLIVER MACLEOD	HT 6103 (FORMERLY HT3103)	4 - 45°	4 - 30°
SECURITY	ASHT	4 - 45°	4 - 30°
ICC	EXCEL 2100-2	4 - 45°	4 - 30°
ENERGY VENT	HT5103	4 - 45°	4 - 30°
GSW	FC	2 - 45° & 2-15°	4 - 30°
SELKIRK METALBESTOS	SSPLUS	2 - 45°	2 - 30°

Installation of all types of factory-built chimney systems is to be in accordance with the chimney manufacturers installation instructions. An appropriate chimney manufacturers anchor base plate is required in order to initiate the twist lock mechanism. Air cooled chimney systems are not recommended in colder climates.

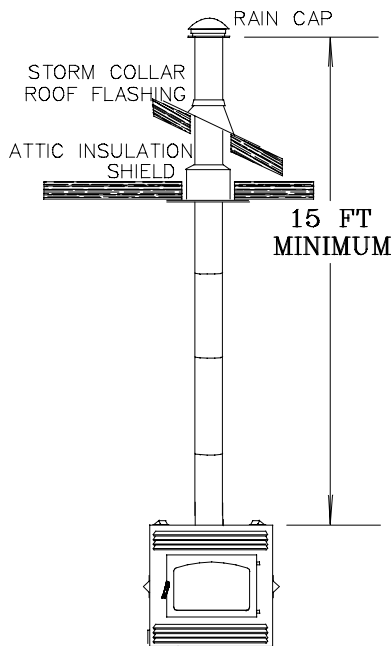

FIGURE 8 - STRAIGHT UP

No Off-Set. Minimum overall chimney height is 15 feet.

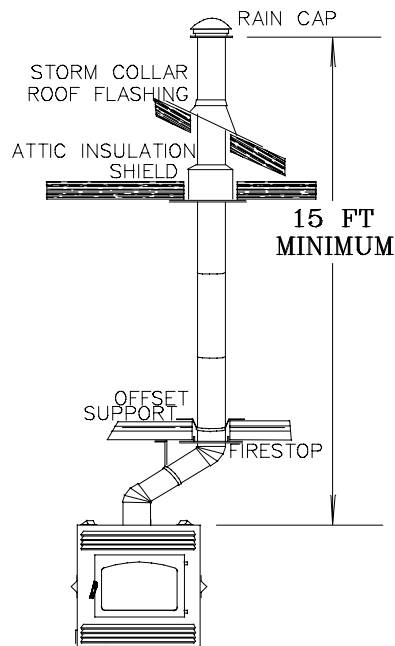

FIGURE 9 - 2 ELBOWS

Single off-set with two 15°, 30° or 45° elbows. Minimum overall chimney height is 15 feet.

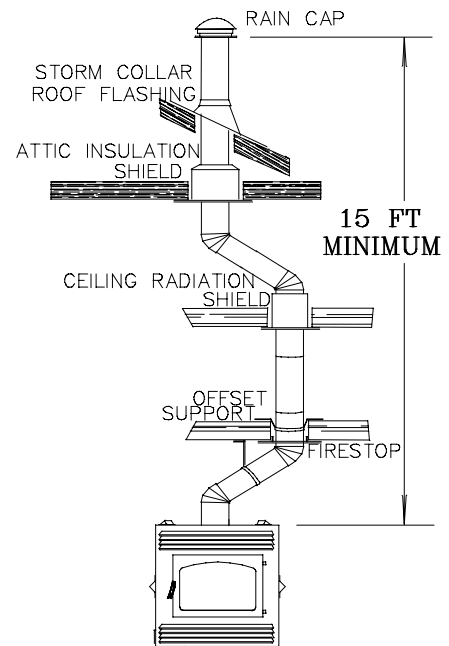
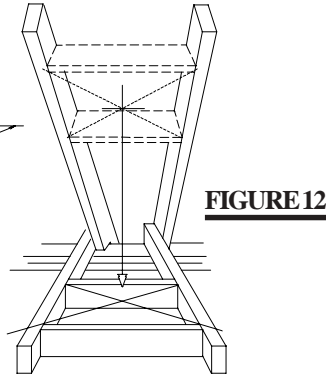
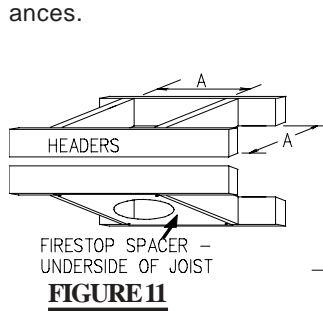

FIGURE 10 - 4 ELBOWS

Double off-set with four 15°, 30° or 45° elbows. Minimum overall chimney height is 15 feet.

1. Move the fireplace into position. Try to center the exhaust flue of the fireplace, midpoint between two joists to prevent having to cut them. Use a plumb bob to line up the centre.
2. Cut and frame an opening in the ceiling to provide a minimum clearance of 2" between the outside of the chimney and any combustible material. **DO NOT FILL THIS SPACE WITH ANY TYPE OF MATERIAL!** Nail headers between the joists for extra support. Firestop spacers must be placed on the bottom of each framed opening in any floor or ceiling that the chimney passes through.
3. Hold a plumb bob from the underside of the roof to determine where the opening in the roof should be. Cut and frame the roof opening maintaining proper 2" clearances.



ADDING CHIMNEY SECTIONS

Add chimney sections, twist locking (clockwise) securely, to the required height. Use a rafter radiation shield whenever the chimney system is enclosed within an attic area.

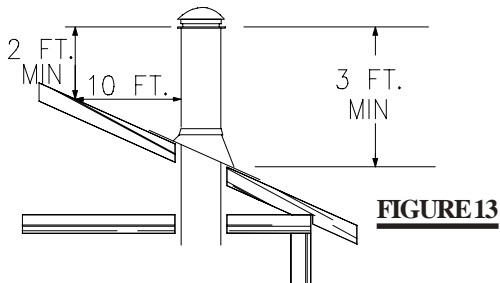

OFFSET CHIMNEY INSTALLATION

An insulated elbow must be used when it becomes necessary to offset the chimney in order to clear a joist or to pass through an upstairs closet.

Attach an elbow to the chimney section, angled toward the offset. Secure with 3 - #8X1/2" sheet metal screws. To achieve the minimum offset, attach and secure a return elbow to the first. To achieve longer offsets, you may install any available length of chimney pipe between the elbows. Supports must be used on the first vertical chimney section after a return elbow.

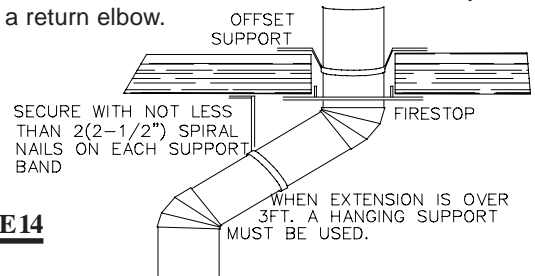

FIGURE 14

INSTALLING FLASHING AND STORM COLLAR

Remove the nails from the shingles above and to the sides of the chimney. Place the flashing over the chimney pipe and slide underneath the sides and upper edge of the shingles. Ensure that the chimney pipe is properly centered within the flashing, giving a 3/4" margin all around. Fasten to the roof on the top and sides. **DO NOT NAIL** through the lower portion of the flashing. Make weather-tight by sealing with caulking. Where possible, cover the sides and top edges of the flashing with roofing material. Apply waterproof caulking, provided with the flashing, around the chimney, 1" above the top of the flashing and push the storm collar down into the caulking. Insert a rain cap onto the top of the last chimney section.

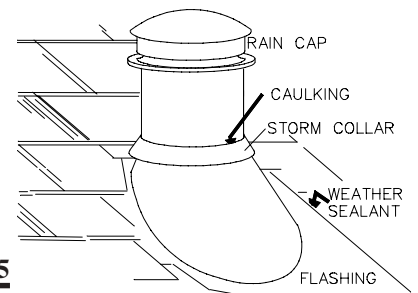

FIGURE 15

CONNECTION TO A MASONRY CHIMNEY

The Napoleon Model NZ25 may be connected to either a lined or unlined masonry chimney.

IF THE CHIMNEY IS LINED, the flues must be made of vitrified clay and be in sizes of 8" square, 8" x 12", or 8" round with a minimum height of 15 feet above the fireplace. *Eight inch round flues are recommended.* Installation must conform to both national and local code requirements.

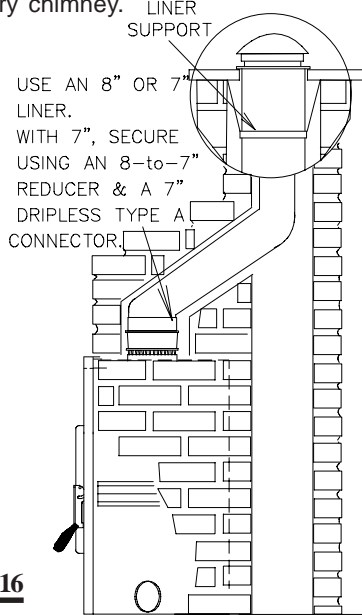

FIGURE 16

IF THE CHIMNEY IS UNLINED, a stainless steel liner listed to Standard ULC-S640M: Liners for New Masonry Chimneys, may be used to connect the fireplace to the chimney. The liner must be continuous from the fireplace to the chimney cap and be installed only per manufacturers instructions. **Figure 16.** In both cases, the chimney structure must be supported by angle iron anchored into the masonry walls. **Figure 17.** The allowable masonry used in chimney construction is 3-1/2" brick, solidly mortared and fully encasing the flue. Ensure there are no leaks.

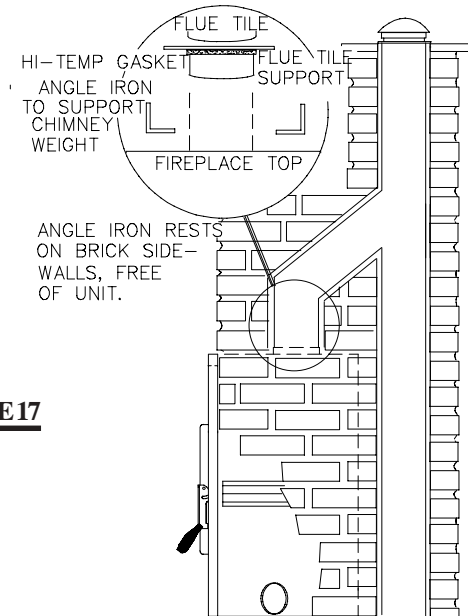

FIGURE 17

In no case is the masonry enclosure to be supported by the NZ25 fireplace. Allow a 1" (one inch) air cavity for expansion.

FINISHING

FIREBRICK REMOVAL:

The fireplace is shipped with the firebricks in place, however if you need to remove them (ease of installation, replacement, etc), follow this sequence:

Remove the ashwell grate. This allows the bricks to be removed in the following order--the four bottom bricks, the bricks along the rear wall (pull the two bricks at the centre, forward and lift the bottom of the bricks out first), the side bricks (tilt the top inward).

ATTACHING THE HANDLE:

Attach the handle as shown so that when the door is closed, the handle will be centred in the slot located on the fireplace front. To achieve this you may have to experiment (on the upper and lower screws) with one of the variations shown. Tighten securely.

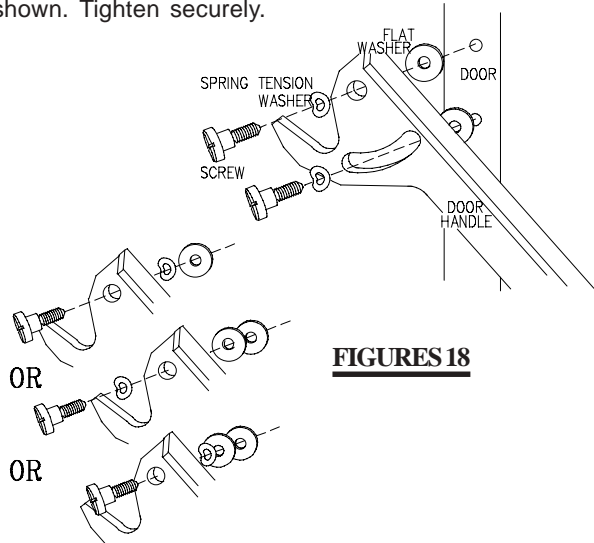

FIGURES 18

OPTIONAL BLOWER INSTALLATION

INSTALLATION TO BE DONE BY A QUALIFIED INSTALLER and must be electrically connected and grounded in accordance with local codes. In the absence of local codes, use the current CSA C22.1 CANADIAN ELECTRICAL CODE.

1. Turn off any electrical power to the fireplace (if applicable). Open the lower louvred control door.

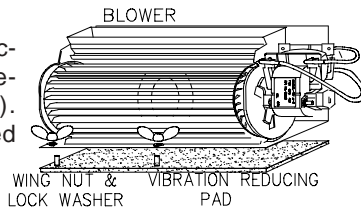

FIGURE 19

2. Locate the vibration reducing pad (one per blower) over the two threaded studs, piercing 2 holes into the pad. The blower must be able to be positioned entirely onto the pad. If only one blower is used, install on the left hand side of the fireplace.

ONE BLOWER INSTALLATION:

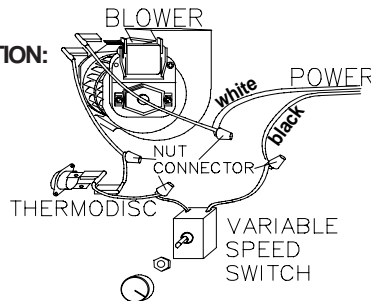

FIGURE 20a

3. Slide the blower to the back of the fireplace taking care not to damage the terminals. Position the blower onto the studs and secure using the lock washers and wing nuts provided. Pull the leads to the front and right side of the ashpan housing.

4. Remove the junction box. Use a nut connector to attach one of the black wires of the variable speed switch to the black power supply wire.

5. Pass the two blower leads and one thermidisc lead through the junction box bushing. The thermidisc is located inside the outer shell, just above the louvre door. **FIGURE 21.** Connect one blower lead to the thermidisc lead using a nut connector and the other blower lead to the white power supply wire using a nut connector.

6. Thread the other thermidisc lead through the junction box bushing and connect to the other black wire of the variable speed switch using a nut connector. Secure ground wire (green) to the threaded weld stud located on the junction box wall. Re-install the junction box. Ensure that the wires will not interfere with the blower.

DUAL BLOWER INSTALLATION:

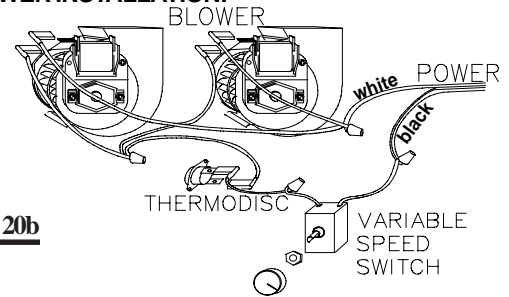

FIGURE 20b

3. Slide the first blower to the back of the fireplace taking care not to damage the terminals. Position the blower onto the studs and secure using the lock washers and wing nuts provided. Pull the leads to the front and right side of the ashpan housing.

4. Slide the second blower into place, position onto the studs and secure as before.

5. Remove the junction box cover located on the lower right outside of the unit. Use a nut connector to attach the black wire of the variable speed switch to the black power wire.

6. Pass the four blower leads and both thermidisc leads through the junction box bushing. Connect one blower lead from each blower and one of the thermidisc leads using a nut connector and connect the other two blower leads to the white power supply wire using a nut connector.

7. Connect the other thermidisc lead to the black wire of the variable speed switch using a nut connector. Secure ground wire (green) to the threaded weld stud located on the junction box wall. Re-install the junction box. Ensure that the wires will not interfere with the blower.

Because the blower is thermally activated, when turned on, it will automatically start approximately 15-45 minutes after lighting the fireplace. Use of the blower increases the output of heat.

Drywall dust will penetrate into the blower bearings causing irreparable damage and must be prevented from coming into contact with the blower or its compartment. Any damage resulting from this condition is not covered by the warranty policy.

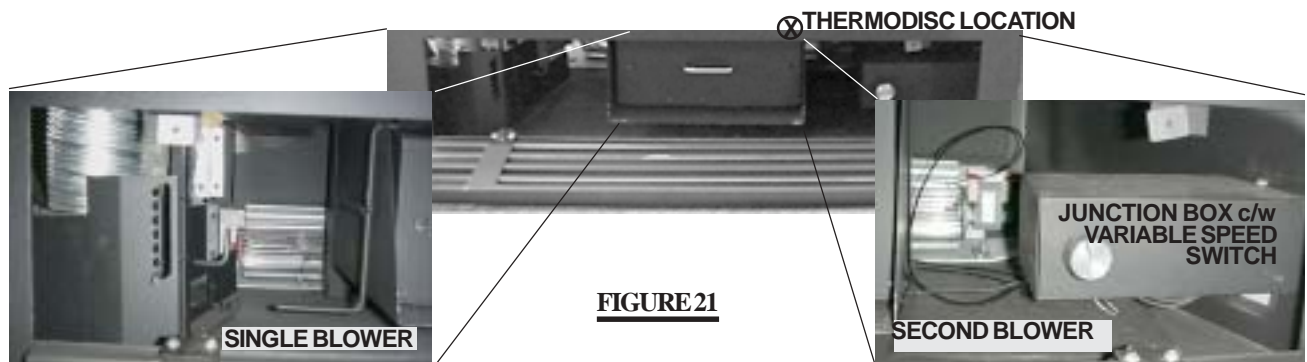

FIGURE 21

NZ25 FEATURES OPERATING INSTRUCTIONS

CONTROLLING COMBUSTION AIR:

If the outside combustion air kit is not used, air may still be drawn directly into the fireplace through the lower louvres. Outside and inside air may be combined by pulling the outside air lever out as far as possible, and turning the lever 90° to its locking position. **Figure 22.**

Should you find a frost build up on the air control box or a draft from the fireplace, close the outside air lever when the fireplace is not in use.

Air control box is shipped with inside air cover plate in open position.

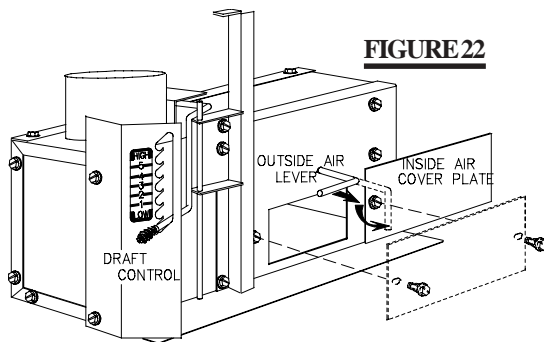

FIGURE 22

ACHIEVING PROPER VENTING ACTION

Draft is the force which moves air from the fireplace up through the chimney. The amount of draft in your chimney depends on the length of the chimney, local geography, nearby obstructions and other forces. Adjusting the draft control regulates the temperature. The draft can be adjusted from a low burn rate with the handle at the bottom setting to a fast burn rate with the handle at the top setting.

Figure 23. Inadequate draft may cause back-puffing into the room and may cause plugging of the chimney. Too much draft may cause an excessive temperature in the fireplace, glowing red fireplace parts or an uncontrollable burn which can all lead to a chimney fire or a permanent damage to the unit. **Do not operate your fireplace for longer than 30 minutes with the draft control on 'HIGH' (fully open).**

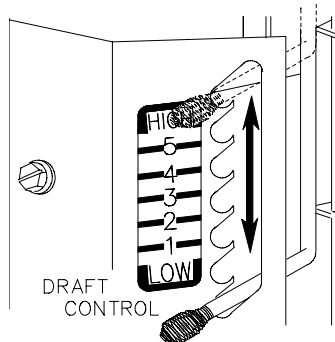

FIGURE 23

FUEL LOADING AND BURN CYCLE

WHEN LOADING THE FIREPLACE, ENSURE THAT THE FIBRE REFRACTORY BAFFLE IS NOT LIFTED UP.

For maximum efficiency, when the fireplace is thoroughly hot, load it fully to the top of the door opening and burn at a medium low setting. The bricks will be nearly all white and the glass mostly clear. The whiteness of the bricks and the cleanness of the glass are good indicators of your operating efficiency.

Not enough heat is produced when only one or two pieces of wood are burned. A minimum of three pieces are needed to encase a bed of coals that sustains the fire. Loosely stacked wood burns quicker than a tightly packed load.

Wood burns in cycles rather than giving a steady output of heat. It is best to plan these cycles around your household routine so that only enough coals are left to start the next load. In the evening, load your fireplace, at least, a half-hour before bed to ensure a good fire that is hot enough to close the draft control for an overnight burn.

Burn only dry seasoned wood. It produces more heat and less soot or creosote. Do not burn ocean beach wood. Its salt content can produce a metal eating acid. When refueling open the door slowly to prevent smoke spillage. Use a pair of long fireplace gloves when feeding the fire. Because these fireplaces burn at the front, they are clean and efficient, but they are also very hot and gloves are useful. Keep a small steel shovel nearby to use as a poker and to remove ashes. Do not store wood within 3 feet (1m) of the fireplace.

FLASH FIRES: A flash fire is a small fire burned quickly when you don't need much heat. After your kindling has "caught", load at least 3 pieces of wood, stacked loosely. Burn with the draft control fully open or closed only slightly.

EXTENDED FIRE: Load your larger pieces of wood compactly, packed close enough to prevent the flames from penetrating it completely. After approximately 30 minutes, depending on the size of the load, close the draft control completely making sure that the fire is not extinguished.

DO NOT OVERFIRE THE FIREPLACE! Overfiring can occur by: a) burning large amounts of smaller wood pieces such as furniture scraps, skids or treated wood; b) vigorously burning large loads of wood with the draft control on "HIGH" (fully open) for long periods of time (one or two hours).

ASH REMOVAL PROCEDURES

A bed of ashes approximately 1 inch deep should be left on the firebox bottom to help maintain a hot charcoal bed. When the fire has burned down and cooled, remove any excess ashes. To use your ash pan, pull the ash dump handle forward to an open position. Rake the excess ashes over the grate and into the ash pan. Close the ash well.

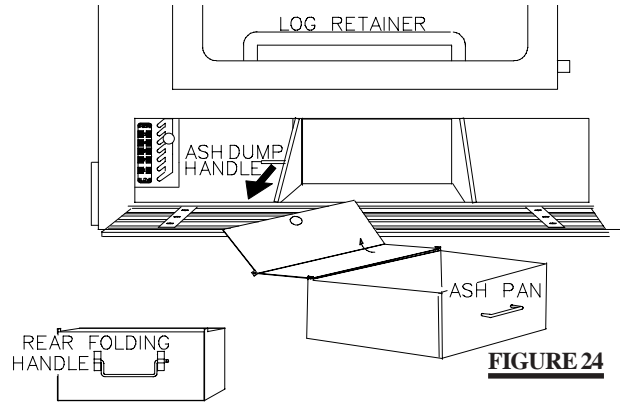

Never operate your fireplace with the ash well in an open position!

This creates a fire hazard that may result in a house/chimney fire, internal damage to the stove or discoloration to the gold plated door (plated finishes are not covered by the warranty). To ensure that the ash well is fully closed, allow the door to snap shut, dislodging anything that may be stuck at the opening.

Flip the cover up onto the ash pan when transporting the ashes to a closed container with a tight fitting lid for storage. Carry the ash pan using the front and back handles. Keep the closed container on a non-combustible floor or ground, well away from all combustible materials. The ashes should be retained in the closed container until all cinders have thoroughly cooled. Cold wood ashes can be used on the garden or compost.

OPERATING INSTRUCTIONS

Remove all source of gasoline or other flammable vapours and liquids in the vicinity of this or other appliances prior to lighting.

When first installed, the fireplace and the steel are cold and must become hot before the fireplace will function well. During the break-in period (the first 2 or 3 fires) create only small, hot fires using kindling; this will allow the firebrick to cure. Do not be alarmed if small hairline cracks develop in the firebrick. This is a normal occurrence and does not pose a safety hazard. The paint may also smell a little for the first few fires as it cures and you may wish to open a door or window to alleviate the smell.

To start, a brisk fire is required. Place loosely crumpled paper on the floor of the fireplace behind the log retainer and cover with dry kindling. Open the draft control fully by moving the lever to "HIGH". Light the paper and leave the door slightly ajar (one inch) until all kindling is burning. To maintain a brisk fire, a hot coal bed must be established and maintained.

Slowly add larger wood (2x4 size pieces). Lay the pieces lengthwise from side to side in the hot coal bed with a shallow trench between, so that the primary air can flow directly into this trench and ignite the fuel above. When the fire seems to be at its peak, medium sized logs may be added. Once these logs have caught fire, carefully close the door.

Closing the door too quickly after refueling will reduce the firebox temperature and result in an unsatisfactory burn.

Remember it is more efficient to burn medium sized wood, briskly, and refuel frequently than to load the fireplace with large logs that result in a smouldering, inefficient fire and dirty glass.

As soon as the door is closed, you will observe a change in the flame pattern. The flames will get smaller and lazier because less oxygen is getting into the combustion chamber. The flames, however, are more efficient. The flames will remain lazy but become larger again as soon as the firebricks have been heated thoroughly and the chimney becomes heated and provides a good draft. At this point, the roaring fire that you see when the door is opened is wastefully drawing heated room air up the chimney -- certainly not desirable. So always operate with the door fully closed once the medium sized logs have caught fire.

You can now add larger pieces of wood and operate the fireplace normally. Once the fireplace is entirely hot, it will burn very efficiently with little smoke from the chimney. There will be a bed of orange coals in the firebox and secondary flames flickering just below the top of the firebox. You can safely fill the firebox with wood to the top of the door.

Can't get the stove operating? Use more kindling and paper. Assuming the chimney and vent are sized correctly and there is sufficient combustion air, the lack of sufficiently dry quantities of *small* kindling is the problem. *Thumb size* is a good gauge for small kindling diameter.

Can't get heat out of the stove? One of two things may have happened. The fireplace door may have been closed prematurely and the fireplace itself has not reached optimum temperature. Re-open the door and/or draft control to re-establish a brisk fire. The other problem may have been wet wood. The typical symptom is sizzling wood and moisture being driven from the wood.

MAINTENANCE

GASKET / BAFFLE REPLACEMENT

At the end of each burning season inspect the baffle located above the secondary air tubes for deterioration. Replace if necessary. At this time also check that the door gasket is not worn or loose. Replace with 1/2" fibreglass rope if necessary.

CREOSOTE FORMATION AND REMOVAL

When wood is burned slowly, it produces tar and other organic vapours which combine with expelled moisture to form creosote. These vapours condense in the relatively cooler chimney flue of a slow burning fire and when ignited, make an extremely hot fire. So, the chimney should be inspected monthly during the heating season to determine if a build-up has occurred. If creosote has accumulated it should be removed to reduce the risk of a chimney fire.

RUN-AWAY OR CHIMNEY FIRE

Run-away fires can be the result of **THREE** major factors:

1. Using incorrect fuel, or small fuel pieces which would normally be used as kindling.
2. Leaving the door ajar too long and creating extreme temperatures as the air rushes in the open door.
3. Burning your fireplace with the ash dump door open.

SOLUTIONS:

1. Do not burn treated or processed wood, coal, charcoal, coloured paper or cardboard.
2. Be careful not to overfire the unit by leaving the door open too long after the initial start-up.
3. Always operate the fireplace with the ash well in a closed position.

WHAT TO DO IF A RUN-AWAY OR CHIMNEY FIRE STARTS:

1. Close the draft fully (lowest position).
2. Call the local fire department.
3. Examine the chimney, attic and roof of the house, to see if any part has become hot enough to catch fire. If necessary spray with a fire extinguisher or water from a garden hose.
4. Do not operate the stove again until you are certain the chimney has not been damaged.

FIRE EXTINGUISHERS AND SMOKE DETECTORS

All homes with a solid fuel burning fireplace should have at least one fire extinguisher in a central location, known to all, and at least one smoke detector in the room containing the fireplace. If it sounds an alarm, correct the cause but do not de-activate or relocate the smoke detector.

WOODPILE MAINTENANCE

Burn only dry, clean unpainted wood that has been seasoned. It produces more heat and less soot or creosote. Freshly cut wood contains about 50% moisture while after proper seasoning only about 20% of the water remains. As wood is burned, this water boils off consuming energy that should be used in heating. The wetter the wood, the less heat is given off and the more creosote is produced.

Both hardwood and softwood burn equally well in this fireplace but hardwood, which is denser, will weigh more per cord and burn a little slower and longer. Firewood should be split, stacked in a manner that air can get to all parts of it and covered in early spring to be ready for burning that fall. Dry firewood has cracks in the end grain.

REPLACEMENTS

ORDERING REPLACEMENT PARTS

Contact your dealer or the factory for questions concerning prices and policies on replacement parts. Normally all parts can be ordered through your Napoleon dealer or distributor. When ordering replacement parts always give the following information:

1. **Model & Serial Number** of the unit.
2. **Installation date** of the unit.
3. **Part Number**
4. **Part Description**
5. **Finish**

REPLACEMENT PARTS

PART NO.	DESCRIPTION
NZ-H333	BLACK DOOR c/w HANDLE & GASKET
NZ-H333G	GOLD PLATED DOOR c/w HANDLE & GASKET
WS-300-04	DOOR GLASS ONLY
EP-562.010	DOOR GASKET
EP-562.016	GLASS GASKET
WS-325-07	LARGE SPRING HANDLE
WS-325-02	SMALL SPRING HANDLE
GA GD-715.11	UPPER LOUVRE - POLISHED BRASS
EP-NZ-018.41	2 PC TOP FIREBRICK BAFFLE
EP-010.243	ASH PAN WITH LID
WS-325-11	ASH PAN HANDLE
WS-690-01	MILLIVOLT THERMOSTAT
WS-690-05	120V THERMOSTAT
NZM 218-B	HOT AIR GRILL 13" X 13" - POLISHED BRASS
WS-090-21	RIGHT FRONT FIREBRICK
WS-090-22	LEFT FRONT FIREBRICK
WS-090-23	REAR FIREBRICK
WS-090-24	BOTTOM LEFT FIREBRICK
WS-090-25	RIGHT SIDE FIREBRICK
WS-090-26	LEFT SIDE FIREBRICK
WS-090-27	BOTTOM RIGHT FIREBRICK
EP-NZ-010.354	LOWER LOUVRE ASSEMBLY- POLISHED BRASS
GZ551	REPLACEMENT BLOWER
WS-062-06	BLOWER - CENTRAL HEATING KIT
KB35	VARIABLE SPEED CONTROL INCL KNOB
WS-690-02	HEAT SENSOR

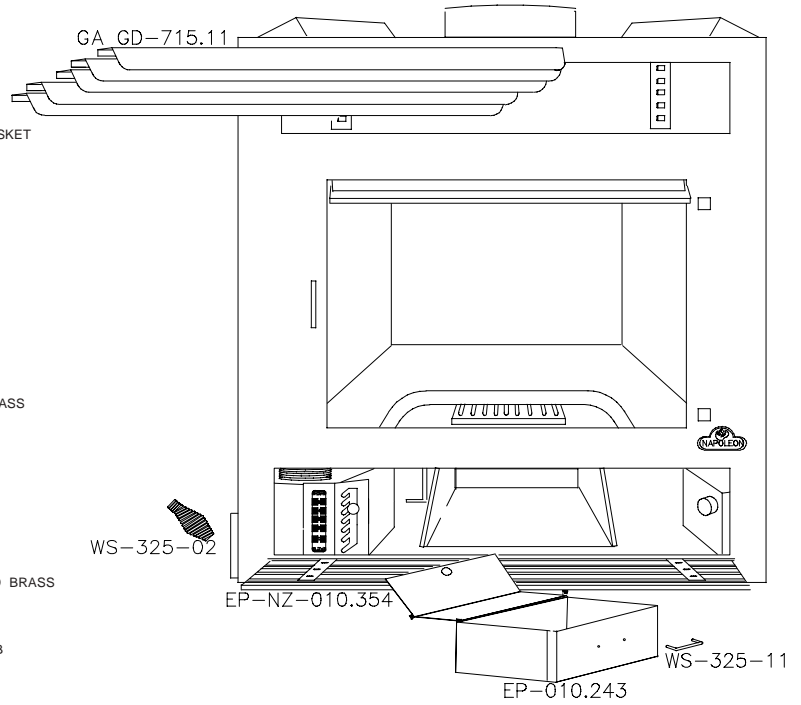

ACCESSORIES / OPTIONS

PART NO.	DESCRIPTION
111KT	OUTSIDE AIR KIT
NZ 690KT	THERMOSTATIC AIR CONTROL KIT
NZ 62 CH	CENTRAL HEATING KIT
NZ62	BLOWER KIT
NZ 220	HOT AIR GRAVITY VENT KIT - 5 FT.
WS-175-02	FLEXIBLE PIPE COUPLER - 8" DIA.
GA GD-010.67	FLEXIBLE VENT SUPPORT ASSEMBLY
NM228-M	FLUE TILE SUPPORT ASSEMBLY
NZ 220-2	HOT AIR GRAVITY VENT EXTENSION KIT - 5 FT. c/w INSULATION SLEEVE
WS-410-05	10FT FLEXIBLE ALUMINUM AIR VENT - 8" DIA.(FOR USE WITH NZ62CH)

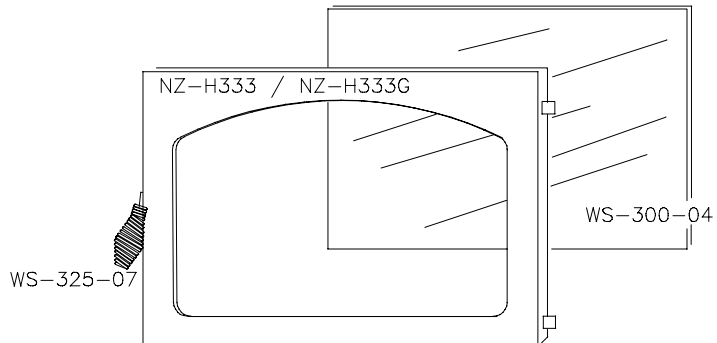
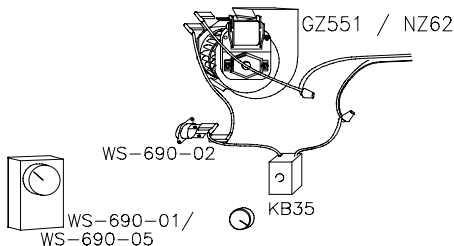
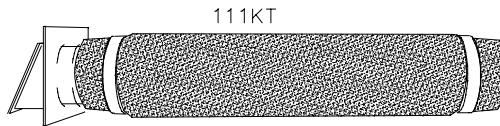
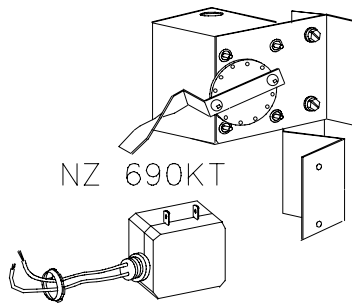
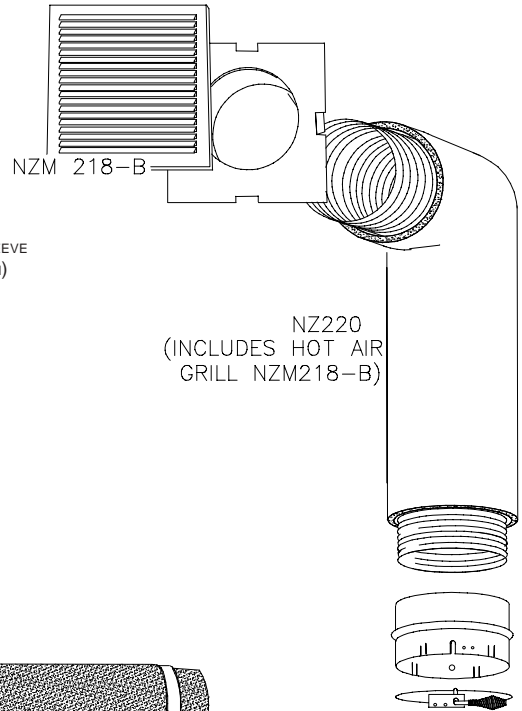

TROUBLE SHOOTING

Build your fire on the floor of the firebox and behind the log retainer only.

Do not block or restrict the hot air outlets or air inlets. This will cause the fireplace to overheat.

Keep fires away from the door .

DOs:

1. **Build a hot fire.**
2. **Use only dry wood**
3. **Several pieces of medium sized wood are better than a few big pieces.**
4. **Clean the chimney regularly.**
5. **Refuel frequently using medium sized wood.**
6. **"Fine Tune" the air settings for optimum performance.**

DON'Ts:

1. **Take ash out immediately. Let it accumulate to a depth of at least one inch. A good ash layer provides for a longer lasting and better burning fire.**
2. **Burn wet wood.**
3. **Close the door too soon or damper down too quickly.**
4. **Burn one large log rather than two or three smaller, more reasonably sized logs.**
5. **Burn at continually 'low setting', if the glass door is constantly blackened. This means the firebox temperature is too low.**

Expansion / contraction noises during heating up and cooling down cycles are normal and to be expected. When first lighting a fire, if the smoke is not quickly drawn into the chimney, there may be a downdraft or cold air in the chimney. Roll up some newspaper, light it and place it near the fireplace flue until the chimney begins to draw. During a firing, open the draft control before opening the fireplace door. Open the door slowly to avoid drawing smoke into the room.

A properly installed Napoleon fireplace should not smoke. If yours does, check the following: Has the chimney had time to get hot? Is the smoke passage blocked anywhere in the fireplace or chimney? Is the room too airtight and the air intake not connected to the outside? Check with a window partly open. Is the smoke flow impeded by too long a horizontal pipe or too many bends? Is it a weak draft perhaps caused by a leaky chimney, a cold outside chimney, too short a chimney, or a chimney too close to trees or a higher roof?

MAINTENANCE

Check your chimney for creosote and soot build-up monthly until a safe frequency for cleaning is established. If accumulation is excessive, clean the chimney. You may want to call a professional chimney sweep to clean it. Both the chimney and the fireplace have to be cleaned at least once a year or as often as necessary. See the Section on Creosote Formation and Removal.