

WAPPOLETON

MODERN NEW ADDITIONS

**ELECTRIC PRESTIGE SERIES MEDIA CONSOLE
PACKAGES AVAILABLE NOW!**



napoleonfireplaces.com

Prestige Series Media Console Packages

Napoleon Prestige Media Console Packages are very modern and each media console package offers a variety of features and functions. The Alanis is all sleek black with two sliding drawers for storage while the Shelton comes with side doors that swing open a full 90 degrees with smoke tempered glass shelves and motion sensor LED lights. Both media consoles come with a convenient top compartment for media components with built in wire management system.

Allure™ Phantom 42 Electric Firebox Features

- 5,000 BTU's and 1,500 Watts
- Matte surround and mesh trim front eliminates reflections
- Crystal clear cube ember bed accents the flames
- Simply plugs into a 120V wall outlet or can be hard wired
- High intensity LED lights provide day or night intensity and require no servicing
- Standard sleep mode allows the on screen controls to dim completely after 10 seconds
- Options of both blue or orange flames, or a combination of both
- Features front vents within the sleek design for maximum zone heating

Media Console Features

Alanis Media Console

- 39"h x 54"w x 18"d
- Contemporary design
- Comes with Allure™ Phantom 42 Electric firebox
- Black finish
- Silver accented drawers
- Electronic media compartment with wire management



Shelton Media Console

- 34"h x 60"w x 20"d
- Transitional design
- Comes with Allure™ Phantom 42 Electric firebox
- 10mm tempered smoke glass top
- Motion Sensor LED Lights
- Electronic media compartment with wire management



Silver Accented Drawers



Convenient Compartment for Media Components



Wire Management System



Brushed Aluminum Round Accent Posts



90 degree Side Swing Doors

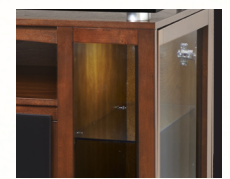



Glass Shelves with Motion Sensor LED Lights





Choose between the transitional design of the Shelton media console (shown above) or the trendy contemporary feel of the Alanis media console (shown below). The debate will be how to decide which of these two media consoles you love the most!





- 

Electric Fireplace
Economical to Operate
- 

Safe To Touch
Never hot enough to burn
- 

Adjustable temperature
Adjust the heat being produced by choosing a temperature
- 

Plug-in
Simply plug in and your fireplace is ready
- 

Eco-Friendly
Only heat the rooms you use most
- 

ULTRA BRIGHT™ LED Lights
Provide day or night intensity
- 

Multi-function remote
Controls flame intensity, flame color option, blower, heat output and timer
- 

WHISPER QUIET™
Operates at a whisper to ensure enjoyment

Specifications

Mantel Name	Product Code	Firebox	Style	Height	Front Width	Depth
Alanis	NEFP42-1815B	ALLURE [™] 42	Entertainment	39"	54"	18"
Shelton	NEFP42-1715BW	ALLURE [™] 42	Entertainment	34"	60"	20"

Firebox Name	Product Code	BTU's (Input)	Watts	Voltage	Amps
ALLURE [™] Phantom 42	NEFL42FH-MT	5,000	1,500	120V AC	15

Certified under Canadian and American National Standards.
 Figures may vary with individual conditions such as floor plan layout, insulation value/heat loss of the house and geographical location.

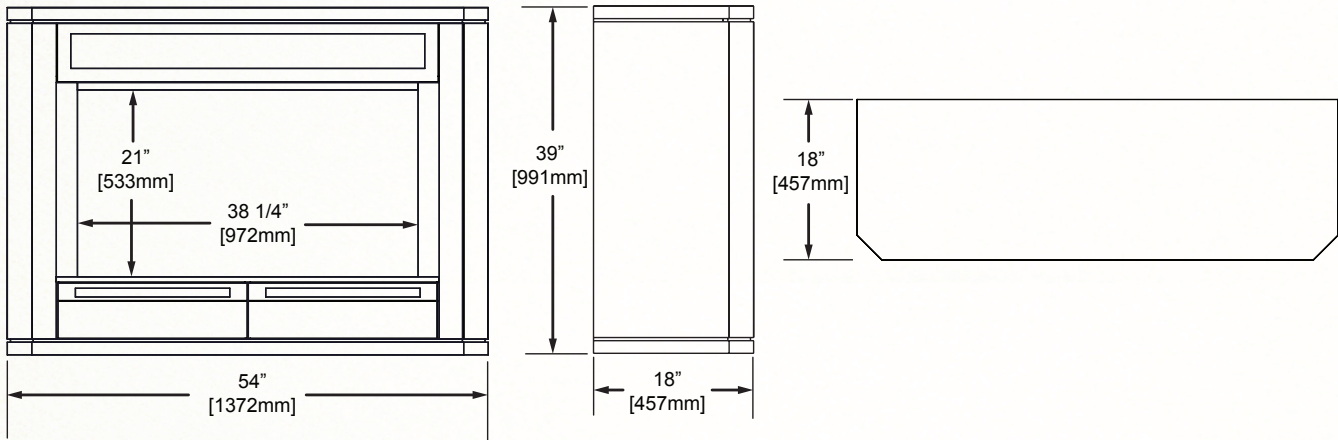

Alanis

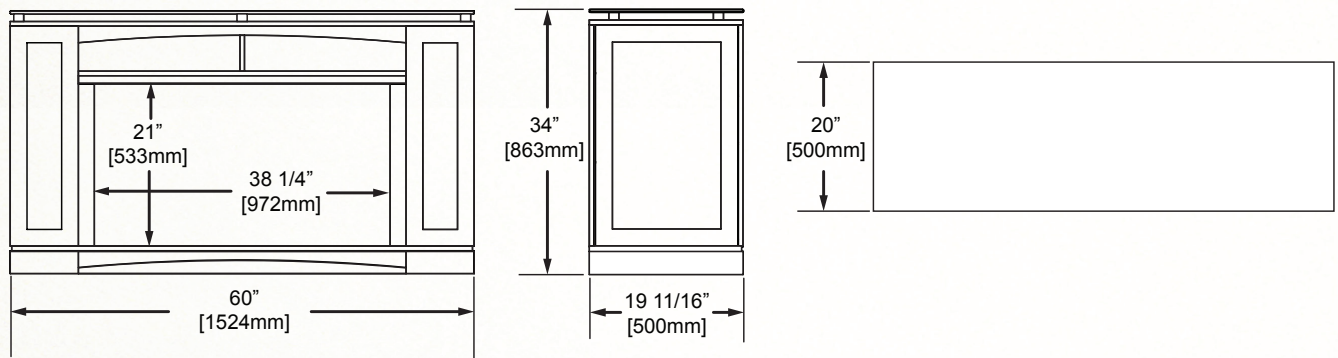

Shelton

Authorized Dealer



24 Napoleon Road, Barrie, Ontario, Canada L4M 0G8
 103 Miller Drive, Crittenden, Kentucky, USA 41030
 7200 Trans Canada Highway, Montreal, Quebec, Canada H4T 1A3

Tel: 705-721-1212
napoleonfireplaces.com



Consult your owner's manual for complete installation instructions, accurate framing dimensions and proper clearances to combustible material. Check all local and national building codes. All specifications are subject to change without prior notice due to on-going product improvements. Products may not be exactly as shown. Napoleon is a registered trademark of Wolf Steel Ltd. © Wolf Steel inc.